

USE AND CARE GUIDE

200 SERIES



250P and 250D



Thank you for equipping your RV or home with an Aqua-Hot hydronic heating system! We value your business and are grateful for the trust you have placed with Aqua-Hot Heating Systems Inc. Our customers are our top priority and we are committed to providing best-in-class products, service, and support.

We understand how important comfort is to you as a recreational vehicle or manufactured home owner; therefore, we have designed a heating system to significantly improve all of your comfort levels. Additionally, the Aqua-Hot hydronic heating system is a low-emissions, fuel efficient system that adds thousands of dollars in value to your RV or home.

We know you must be eager to get underway, but take time to read the entire Use and Care Guide and understand your Aqua-Hot unit. This guide should be maintained in legible condition and kept in a safe, accessible location for future review

Should you have any suggestions how we can better serve you, please do not hesitate to contact us at +1 (800) 685-4298 or +1 (303) 651-5500.

The Aqua-Hot heating system is protected by the finest warranty in the industry (read about it on page 20.)

IMPORTANT NOTE:

- A qualified installer or service technician must perform equipment installation or service. Contact Aqua-Hot for Factory Authorized Service Centers or Certified Technicians located near you at www.aquahot.com/service-help, or call us at +1 (800) 685-4298 or +1 (303) 651-5500.
- Warranty work must be performed by an Aqua-Hot Factory Authorized Service Center

IMPORTANT NOTE:

- Your on-product identity label contains specifications of your unit. Factory settings may be adjusted by the RV or home manufacturer, confirm final setting with your dealer.



- If the information in this guide is not followed exactly, a fire or explosion may result, causing property damage or personal injury.



Comfort Zone #1: Comfortable Cabin Heat.

Get heat where you want it, when you want it! This Aqua-Hot system puts heat where you need it. Therefore, your interior temperatures will be just right. Don't hesitate to crank up the heat because the Aqua-Hot system doesn't remove moisture from the air. From now on, you will have to blame the dry skin and itchy eyes on Mother Nature!

Comfort Zone #2: Quiet Operation

Say goodbye to rude awakenings from the forced air furnace, you're an Aqua-Hot owner now! The Aqua-Hot is quiet when operating, so you'll never have to turn up the TV, yell across the room, or have an interrupted night of sleep again due to your heating system.

Comfort Zone #3: Continuous, Hot Water

Take long, guilt free showers knowing there is no recovery time for the next shower or load of laundry. The freedom to take a shower when you want makes your experience feel much more like home.

Comfort Zone #4: Low Emissions

Aqua-Hot's new low emission systems are fumeless and odorless. It's good for you, good for your neighbor, and good for the environment.

Comfort Zone #5: Over 200 Factory-Trained Service Centers

You won't need to service your Aqua-Hot often, but when you do, you can be confident in our Certified Service Centers that are close by and trained to assist you with all of your Aqua-Hot specific needs.

Comfort Zone #6: Adds Value

The NADA Recreational Vehicle Guide lists Aqua-Hot as adding thousands of dollars to the value of an RV. That value will pay off when it's time to trade up or sell.

Comfort Zone #7: Low Fuel Costs

There's no need to burn propane each time heat or hot water is needed. The Aqua-Hot heats a boiler tank and uses the heat stored in the liquid of the boiler tank to provide interior heat. Aqua-Hot's 200 series uses TribidHot™ technology to power the Aqua-Hot system by pulling heat from one or a combination of heat sources. Use the electric setting to keep the boiler tank up to temperature and for light heating needs, Use the burner when colder conditions require or when using hot water.

Contents

Contents and Cautions 3
 Safety Precautions and Instructions 4
 250P Operation and Safety Product Decal 5
 Component Locations 6
 Hydronic Heating System Features 10
 Product Label Location..... 10

Operating Instructions

Activating the Aqua-Hot Heating System 11
 Burner and Electric Switches 11
 Interior Heating Operation..... 11
 Hot Water Operation..... 11
 Operational Flow Chart..... 12

Maintenance

Maintenance Schedule 13
 Replenishing the Antifreeze/Water Solution..... 13
 Annual Maintenance 13

Winterization and Disinfection

Winterizing the Domestic Water Heating System 14
 De-Winterizing the Domestic Water Heating System 14
 Disinfecting the Domestic Water Heating System 14

Troubleshooting

General Information 15
 Fluid Level Sensor 15

Appendices

Appendix A: Antifreeze Types 16
 Appendix B: Antifreeze Mixture/Water Quality 16
 Appendix C: Antifreeze Terms and Mixture Ratio..... 16
 Appendix D: Measuring Antifreeze Concentration 18

Owner's Service Log 19

Warranty

Limited Warranty Statement..... 21

Caution Notes

As you read this information, take particular note of the NOTICE, CAUTION, WARNING, and DANGER symbols when they appear. This information is important for safe and efficient use of the Aqua-Hot equipment.



NOTICE signals a situation where potential damage to the equipment could occur.



CAUTION signals a situation where potential harm or risk of minor or moderate injury could occur if instructions are not followed.



WARNING signals a hazardous situation where potential harm, risk of serious injury or death could result if you do not follow instructions.



DANGER signals a situation where immediate risk of serious injury or death will result if you do not follow instructions.

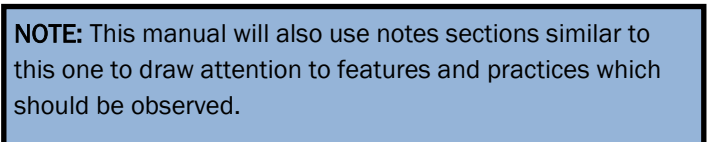

The Aqua-Hot Heating System

Read and understand all instructions before installing this unit.

- Read this owner’s manual before installing or using the Aqua-Hot system to reduce the risk of injury to persons or damage to equipment.
- The product identity label contains specifications of the unit, to what standard it has been tested, and important safety notices.
- The Aqua-Hot must be installed in a compartment that is closed off from living quarters and accessible only from the outdoors.
- Propylene glycol based antifreeze “Generally Recognized As Safe” (GRAS) by the FDA must be utilized for antifreeze and water heating solution.
- An interlock switch prevents the Aqua-Hot heater from operating when the cover is not installed in the correct position.
- Should any additional assistance be needed, please contact the Product Application Department at +1 (800) 685-4298 or +1 (303) 651-5500.
- Do not store or use gasoline or other flammable vapors or liquids in the vicinity of this or any other appliance
- Disconnect electric wiring to the Aqua-Hot system before



welding or plasma cutting the RV or home to avoid damage to equipment

- Air pressure to the tank must NOT exceed 20PSI or it will cause damage
- The Aqua-Hot exhaust is HOT and must be kept away from heat sensitive material
- Use caution when working on or near the propane gas system
- DO NOT connect the 12V DC power to the Aqua-Hot if the RV or home requires welding
- At maximum operating temperatures, the coolant will be very hot and scalding hot vapor or coolant may result in

serious burns or injury

- DO NOT activate the burner until the antifreeze and water heating solution has been added to the boiler tank to avoid serious damage to the heater

WHAT TO DO IF YOU SMELL GAS

- Evacuate all persons from the vehicle



- Shut off the gas supply at the gas container or source
- Do not touch any electrical switch or use any phone or radio in the vehicle
- Do not start the engine or electric generator (if equipped)
- Contact the nearest gas supplier or qualified service technician for repairs
- If you cannot contact the nearest gas supplier or qualified service technician, contact the nearest fire department
- Do not turn on the gas supply until the gas leak or leaks (if relevant) has been repaired
- Installation and service must be performed by a qualified installer, service agency or gas supplier

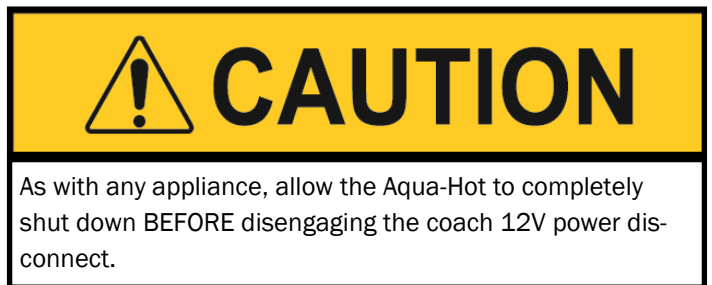

The Aqua-Hot’s exhaust is HOT!

- Do NOT park in areas where dry conditions exist (i.e. grassy, dry fields)
- Do NOT operate the burner inside an enclosed building
- The heater must be switched OFF when refueling

<h2 style="text-align: center; background-color: #0056b3; color: white; padding: 10px;">NOTICE</h2>	<h2 style="text-align: center; background-color: #008000; color: white; padding: 10px;">SAFETY INSTRUCTIONS</h2>	<h2 style="text-align: center; background-color: #008000; color: white; padding: 10px;">OPERATING INSTRUCTIONS</h2>
<p>This appliance operates on both AC and DC power.</p>	<p>A. This appliance does not have a pilot. It is equipped with an ignition device, which automatically lights the burner. Do not try to light the burner by hand.</p> <p>B. BEFORE OPERATING, smell all around the appliance area for gas. Be sure to smell next to the floor because some gas is heavier than air and will settle on the floor.</p> <p>WHAT TO DO IF YOU SMELL GAS</p> <ul style="list-style-type: none"> -Do not try to light any appliance. -Do not touch any electric switch; do not use any phone in your building. -Immediately call your gas supplier from a neighbor's phone. Follow the gas supplier's instructions. -If you cannot reach your gas supplier, call the fire department. 	<p>1. STOP! Read the safety information to the left on this label.</p> <p>2. This appliance is equipped with an ignition device, which automatically lights the burner. Do not try to light the burner by hand.</p> <p>3. Ensure that the gas control valve is turned on. Follow "B" in the safety information to the left on this label. If you don't smell gas, go to the next step.</p> <p>4. Refer to the Owner's Manual for information regarding normal operation of this heating system.</p> <p>5. If the appliance will not operate, follow the instructions "To Turn Off Gas To Appliance" below on this label and refer to the Owner's Manual troubleshooting section or call the technical support department at 1-800-685-4298.</p>
<p>Failure to winterize your heater, when stored in freezing temperatures, will result in serious damage to the products domestic hot water heating system.</p>	<p>C. Use only your hand to push in or turn the gas control knob. Never use tools. If the knob will not push in or turn by hand, don't try to repair it, call a qualified service technician. Forced or attempted repair may result in a fire or explosion.</p> <p>D. Do not use this appliance if any part has been under water. Immediately call a qualified service technician to inspect the appliance and to replace any part of the control system and any gas control which has been under water.</p>	<h3 style="background-color: #008000; color: white; padding: 5px;">TO TURN OFF GAS TO APPLIANCE</h3> <ol style="list-style-type: none"> 1. Turn off all electric power to the appliance if service is to be performed. 2. Set all interior thermostats to their lowest setting. 3. Turn the gas control knob located on the heater's propane inlet port clockwise to the "OFF" position.
<p>Air pressure applied to the tank must not exceed 20 psi. Excess pressure will result in internal damage.</p>	<h2 style="text-align: center; background-color: #008000; color: white; padding: 10px;">CONSIGNES DE SÉCURITÉ</h2> <p>A. Cet appareil ne compare pas de veilleuse. Il est muni d'un dispositif d'allumage qui allume automatiquement le brûleur. Ne tentez pas d'allumer le brûleur manuellement.</p> <p>B. AVANT DE FAIRE FONCTIONNER, reniflez tout autour de l'appareil pour détecter une odeur de gaz. Reniflez près du plancher, car certains gaz sont plus lourds que l'air et peuvent s'accumuler au niveau du sol. QUE FAIRE SI VOUS SENTEZ UNE ODEUR DE GAS :</p> <ul style="list-style-type: none"> - Ne pas tenter d'allumer d'appareil. - Ne touchez à aucun interrupteur ; ne pas vous servir des téléphones se trouvant dans le bâtiment. - Appelez immédiatement votre fournisseur de gaz depuis un voisin. Suivez les instructions du fournisseur. - Si vous ne pouvez rejoindre le fournisseur, appelez le service des incendies. 	<h2 style="text-align: center; background-color: #008000; color: white; padding: 10px;">INSTRUCTIONS DE MISE EN MARCHÉ</h2> <p>1. ARRÊTEZ! Lisez les instructions de sécurité sur la portion à gauche de cette étiquette.</p> <p>2. Cet appareil est muni d'un dispositif d'allumage qui allume automatiquement le brûleur. Ne tentez pas d'allumer le brûleur manuellement.</p> <p>3. Assurez-vous que la soupape de contrôle de gaz est bien ouverte. Passez à l'étape B des instructions de sécurité sur la portion à gauche de cette étiquette. S'il n'y a pas d'odeur de gaz, passez à l'étape suivante.</p> <p>4. Référez au Manuel du propriétaire pour des informations au sujet du fonctionnement normal de ce système de chauffage.</p> <p>5. Si l'appareil ne fonctionne pas, veuillez suivre les instructions « Pour couper le gaz vers l'appareil » ci-dessous sur cette étiquette et référez à la section Dépannage du Manuel du propriétaire ou appelez le service de soutien technique au 1 800 685 4298.</p>
<p>For detailed information, reference the owner's manual or contact Aqua-Hot Heating Systems, Inc. at 800-685-4298.</p>	<h2 style="text-align: center; background-color: #0056b3; color: white; padding: 10px;">AVIS</h2> <p>Cet appareil fonctionne à la fois sur une alimentation a.c. et c.c.</p> <p>Utiliser uniquement un antigel de chaudière à base de propylène glycol non toxique avec des additifs généralement jugés sans danger « GJSD » (« GRAS » /generally recognized as safe) par la FDA.</p> <p>Ne pas hiverner l'appareil de chauffage lorsqu'il est entreposé à des températures inférieures à 0 ° C provoquera de graves dommages au système de chauffage d'eau chaude domestique du produit.</p> <p>La pression d'air appliquée au réservoir ne doit pas dépasser 20 psi. Tout excès de pression provoquera des dommages internes.</p> <p>Pour des informations détaillées, consulter le manuel d'utilisation et contacter Aqua-Hot Heating Systems, Inc. en composant le 800-685-4298.</p>	<h3 style="background-color: #008000; color: white; padding: 5px;">COMMENT COUPER L'ADMISSION DE GAZ DE L'APPAREIL</h3> <ol style="list-style-type: none"> 1. Coupez l'alimentation électrique de l'appareil s'il faut procéder à l'entretien. 2. Réglez tous les thermostats intérieurs à leur réglage le plus bas. 3. Tournez le bouton de contrôle du gaz, situé sur le port d'entrée de propane du chauffe-eau, vers la droite à la position « OFF » (Arrêt).



1. Domestic Cold Water Inlet
2. Domestic Hot Water Outlet
3. 12V DC Harness Junction
4. Diesel Fuel Connections
5. Expansion Tank Connection
6. Heating Zone Outlet Port
7. Heating Zone Return Port
8. 120V AC Connection
9. Interlock Switch
10. 3-Way Valve
11. Diesel Burner Assembly
12. Boiler Tank
13. Tempering Valve
14. Diesel Burner Controller
15. Zone Circulation Pump
16. Drain Valve
17. Access Cover Screw

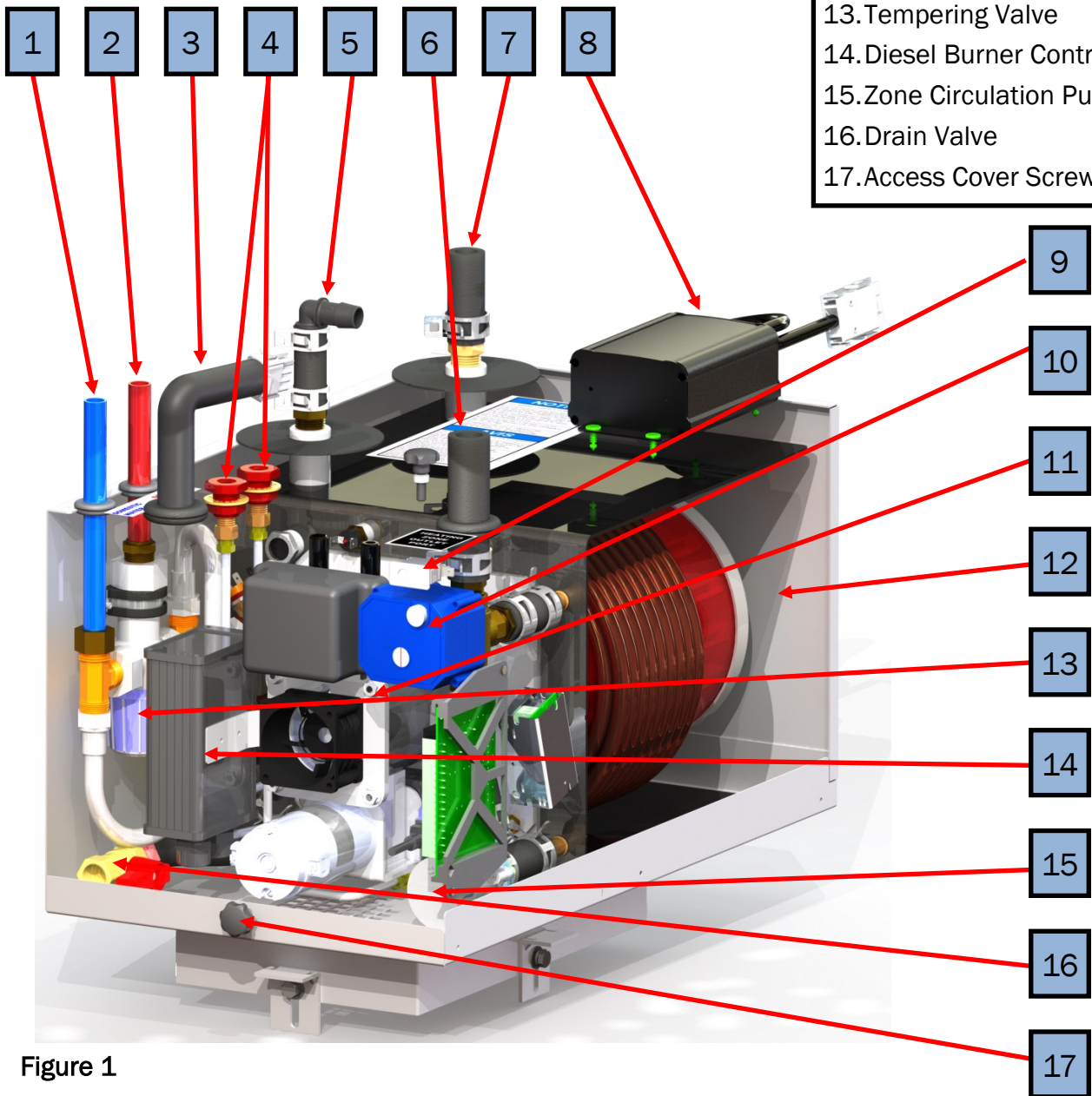

Figure 1

- 1. Domestic Cold Water Inlet
- 2. Hot Water Outlet
- 3. Propane Inlet Ball Valve
- 4. 12V DC Harness Junction
- 5. Expansion Tank Connection
- 6. Heating Zone Outlet Port
- 7. Heating Zone Return Port
- 8. 120V AC Electrical Relay Box (250P Only)
- 9. Propane Burner Assembly
- 10. Tempering Valve
- 11. Boiler Tank
- 12. 3-Way Valve
- 13. Propane Burner Controller
- 14. Interlock Switch
- 15. Drain Valve
- 16. Zone Circulation Pump
- 17. Access Cover Screw

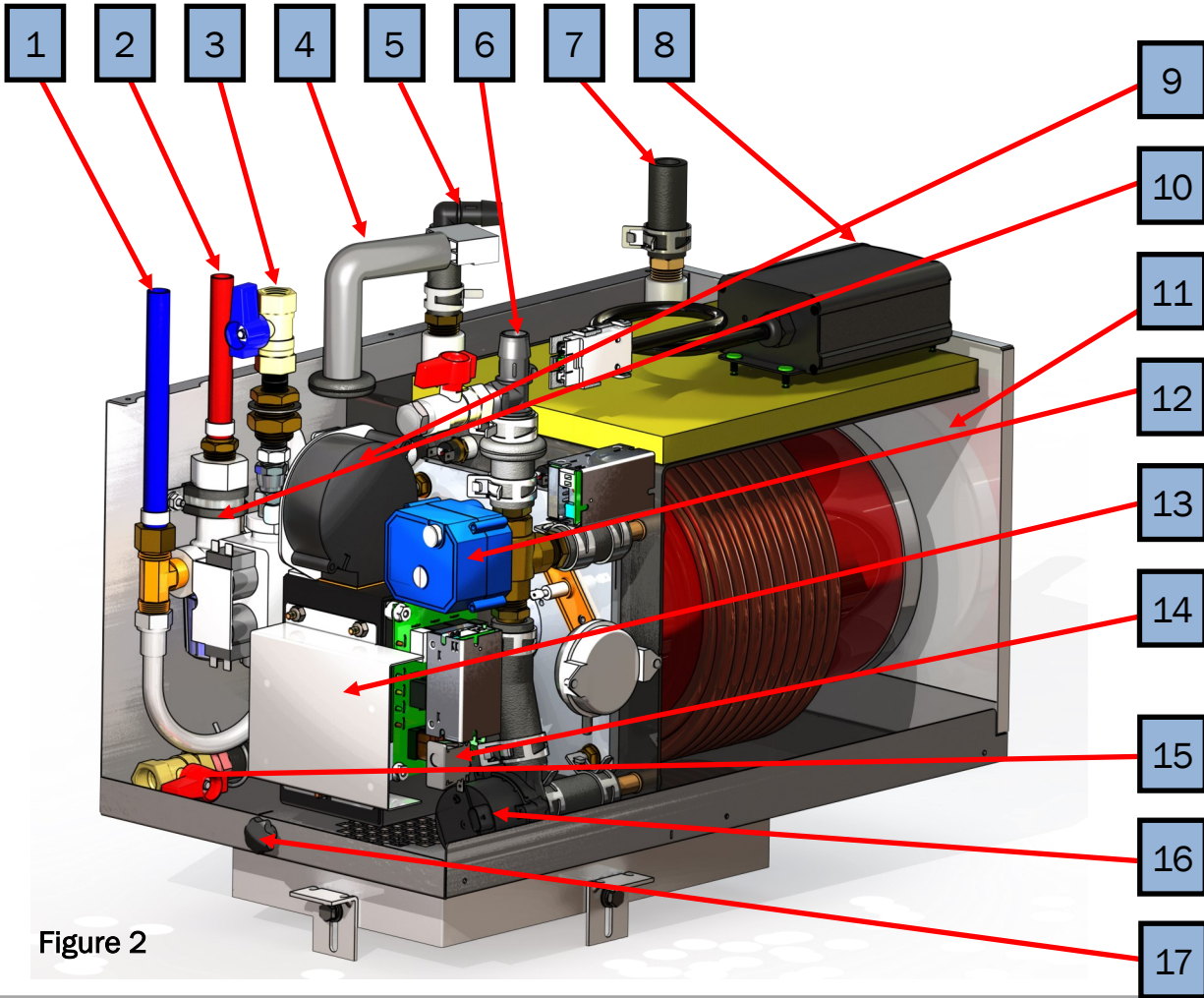

Figure 2

Aqua-Hot System Features

The Aqua-Hot Heating System is a Low-Emissions Hydronic Heating System that significantly improves your level of comfort, decreases harmful emissions released into the atmosphere, and adds thousands of dollars in value to your coach.

The Aqua-Hot Heating System is two systems in one:

1. Interior Heating System: Provides quiet, comfortable interior heat and even temperatures
2. Tank-less Hot Water System: Provides a steady flow of continuous hot water

The Aqua-Hot is powered by TribridHot™ technology and uses one or a combination of the following heat sources:

1. **Burner:** This is the Aqua-Hot's most powerful heat source. The burner must be on for the Aqua-Hot to provide continuous hot water. The burner must also be on for the Aqua-Hot to provide interior heat in colder conditions.
2. **120V AC Electric Element (250P and 250D only):** When plugged into shore power, the electric element lets you use the power you are already paying for to provide heat in mild conditions and meet your light duty hot water needs.

Bring the Aqua-Hot to Operating Temperature:

Your Aqua-Hot hydronic heating system heats a water and antifreeze solution that is stored in the Aqua-Hot's boiler tank. This water and antifreeze solution must be up to operating temperature before the Aqua-Hot will provide interior heat or continuous hot water. To bring the Aqua-Hot up to temperature, turn the Burner switch to the ON position. Depending on the ambient temperature, it may take up to ten minutes for the Aqua-Hot's water and antifreeze solution to reach operating temperature.

Once the tank is up to operating temperature, the electric element may be used to maintain the operating temperature and provide light duty hot water and interior heat. This feature is only available on the 250P and 250D models.

For continuous hot water, or for heat in colder conditions the burner must be on.



NOTE: The product label is attached to the side of the Aqua-Hot and provides a ready reference to specifications, test standards and important safety notices.



For installation only in a compartment that is completely closed off from living quarters and accessible only from the outdoors.
Combustion Air MUST BE supplied from outside the vehicle.
 Suitable for water (potable) heating and space heating.
THIS APPLIANCE OPERATES ON DC POWER.
USE COPPER CONDUCTORS ONLY!
 Use a 20-Amp fuse for over-current protection for the DC power supply.
 Mount the Heater near a bay/storage door so that the Access cover can be easily removed for service.

For Detailed Information, reference the Owner's Manual or contact Aqua-Hot Heating Systems Inc. at 1-800-685-4298.

Minimum Service Clearances
 Front - Open Access
 Back - 1 inches
 Top - 8 inches
 Sides - 1 inches

This appliance must be installed in accordance with local codes or, in the absence of local codes, the Standard for Recreational Vehicles, ANSI A119.2/NFPA 119.2 or CAN/CSA-Z240 RV.

 **For Direct Vent Installation in a Recreational Vehicle.**
 Meets or Exceeds: ANSI Z21.10.1/C SA 4.1
 UL 307B, UL 174
 CSA-C22.2 No. 110-94

Max Tank Pressure	0 PSI
Watts (DC)	92.5
Tank Capacity	3.7 gal
Orifice Size	0.089
Volts/Amps	12VDC, 7.7A
Input Firing Rate	60000 BTU/HR, 17.6 kWh
Minimum Inlet Pressure	8"wc (in. H ₂ O)
Manifold Pressure	10"wc (in. H ₂ O)
Max Inlet Pressure	13"wc (in. H ₂ O)
Fuel Type	PROPANE

Model Number: 200P
 Serial Number: A200-170002

7501 Miller Drive • Frederick, CO 80504 • 1.800.685.4298 • www.aquahot.com

Patent Pending

Figure 3

NOTE: This Aqua-Hot product utilizes a propylene glycol based antifreeze and water heating solution. This propylene glycol based solution is a boiler type antifreeze that is "Generally Recognized As Safe" (GRAS) by the FDA. For additional information regarding this "GRAS" antifreeze product, see the Care & Maintenance section of this guide, or contact the Aqua-Hot Heating Systems Technical Support department at +1 (800) 685-4298 or visit our website at www.aquahot.com.

Operational Overview:

The heating features are powered by either a 12V DC propane burner, or a 12V DC diesel burner. In addition to the burner, the 250P and the 250D also include a 120V AC electric heating element. These maintain the temperature of the Aqua-Hot’s antifreeze and water heating solution to provide hot water and interior heat

- **Burner**—The burner is the Aqua-Hot’s primary and most powerful heating source. The burner provides for all heating and hot water needs. It can be activated by turning the burner switch to the ON position. Reference figure below if necessary
- **Electric (250P and 250D only)**—The electric element is the Aqua-Hot’s secondary heat source and can be used when plugged into shore power. The electric element provides heat when moderate temperatures exist (50 °F or higher) and/or when there is a low demand for hot water. It can be activated by turning the electric switch to the ON position. Reference figure below if necessary.



NOTICE

Do not operate the burner and/or electric element without anti-freeze and water heating solution in the Aqua-Hot’s boiler tank. To do so will cause serious damage to the heater.

Switches:

The Aqua-Hot heating system is controlled by one or two switches; the burner switch and/or the electric element switch (250P and 250D only.) When one or both switches are in the on position, it will supply the necessary heat to the boiler tank. Keep in mind that the Aqua-Hot must be at operating temperature for the heating zones and hot water to function properly.

Different manufacturers may use different types of switches. Please contact the dealer or manufacturer for the exact type, location, and switch operation.

WARNING

The Aqua-Hot’s exhaust is HOT! Do NOT park in areas where dry conditions exist (i.e., grassy, dry fields.) Do NOT operate the burner inside an enclosed building. The heater must be switched off when refueling.

Controlling Heat Levels with Room Thermostat:

When the Aqua-Hot is on and up to operating temperature (see previous page,) and the interior room thermostat is set to heat, adjust the room thermostat to the desired temperature and it will automatically activate the Aqua-Hot’s heating functions to maintain the desired interior temperature.

Different manufacturers may use different types of thermostats. Please contact the dealer or manufacturer for the exact type, location, and thermostat operation.

Using Hot Water:

When the Aqua-Hot is on and up to operating temperature (see previous page,) simply open a hot water faucet and a continuous supply of hot water will be present within a few seconds.

The Aqua-Hot system is known as a tankless, continuous water heating system because hot water is not stored in a tank. Instead, when the burner and/or electric element switch (250P and 250D only) is ON and the Aqua-Hot is at operating temperature, the water is automatically heated as it is being used. Remember, the burner must be on for continuous hot water.

Operational Flow Chart

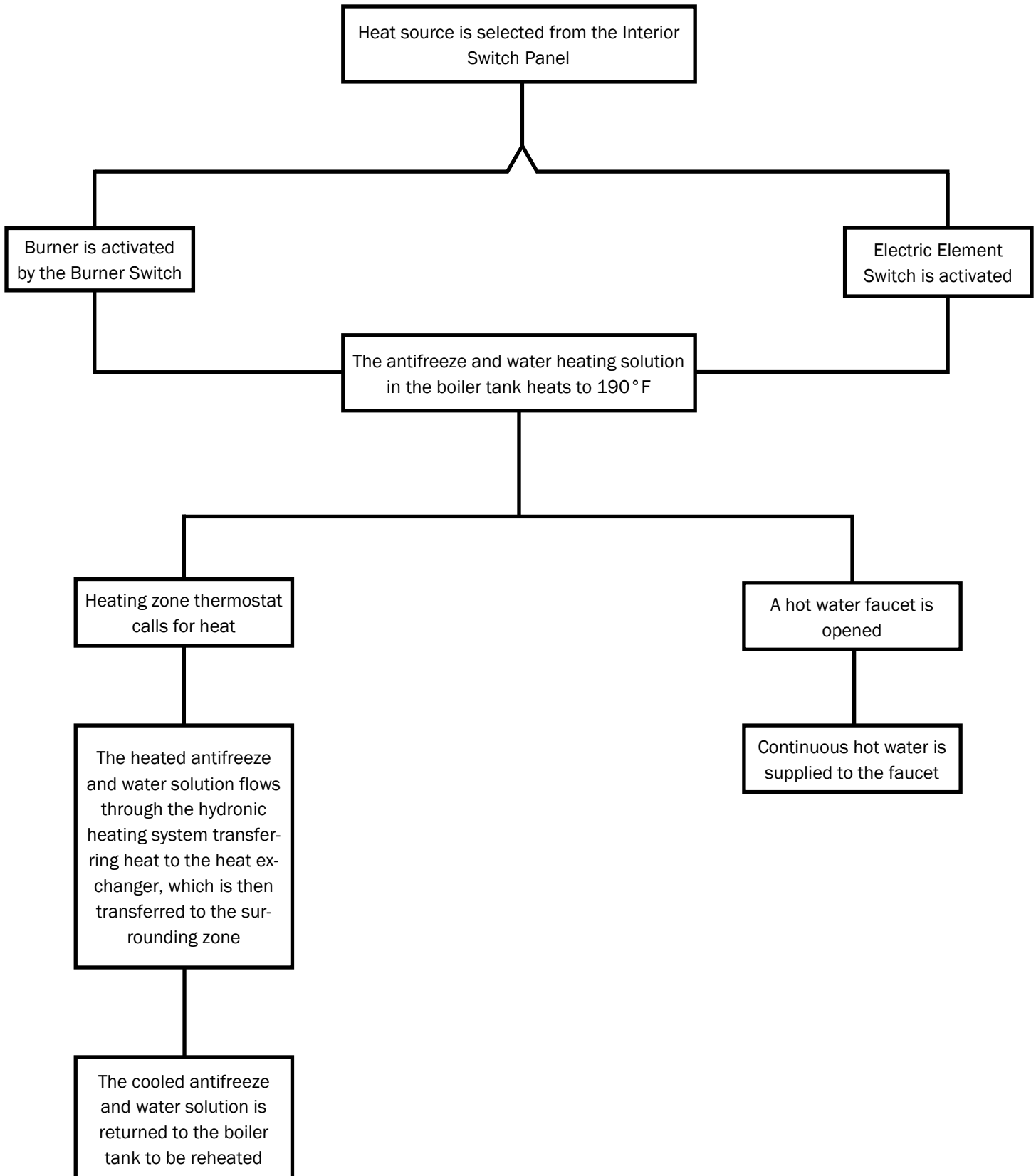

Maintenance Schedule

Monthly Maintenance

Check the Aqua-Hot's antifreeze and water heating solution to ensure that it is at the proper level. This can be accomplished by visually checking the coolant level in the Aqua-Hot's expansion tank; reference figure 5, page 14.

Please note that the coolant level should be checked **ONLY** when the Aqua-Hot is at maximum operating temperature. This should be done immediately after the burner cycles off.

At maximum operating temperature, the antifreeze and water heating solution should be at the level marked "HOT" on the expansion tank.

Run the interior heating zones until you feel warm air blowing out of the heat exchangers.

Run the burner once a month. This will ensure proper operation of the burner.

Replenishing the Antifreeze and Water Heating Solution

If the antifreeze and water heating solution needs replenishing, remove the cap for the expansion bottle and fill it to the "HOT" mark. Replace the expansion bottle cap when this is complete.

Reference appendices A through C in order to determine the correct ratio of antifreeze to water, the proper type of antifreeze, and the water quality recommendations for the Aqua-Hot antifreeze and water heating solution. Reference appendix D for the proper tool and instructions for usage in measuring the system's antifreeze mixture ratio.

Annual Maintenance

Propane

Remove and clean the flame detector with a scotch-brite pad. Reference the Aqua-Hot's Service and Parts manual for spare parts information and detailed replacement instructions. Contact the Aqua-Hot Heating Systems Technical Support Department at +1 (800) 685-4298 for assistance. Otherwise, locate the nearest Aqua-Hot Service Center, or visit our web site at www.aquahot.com.

Diesel

To keep the diesel burner running smoothly, a tune-up, or annual service should be performed on the unit. An annual service consists of a new fuel nozzle and fuel filter. To ensure best diesel-burner performance, always use the recommended fuel nozzle and fuel filter when replacing these parts.



DANGER

When the Aqua-Hot is at maximum operating temperature, the coolant will be very hot. If the Aqua-Hot's heating system is accessed, scalding by hot vapor or coolant could result. Before cleaning or servicing, disconnect all power supplies



WARNING

DO NOT operate the burner and/or the electric heating element without the antifreeze and water heating solution in the Aqua-Hot's boiler tank. Doing so will cause serious damage to the heater.

Propylene glycol that is "Generally Recognized As Safe" by the FDA must be utilized for the antifreeze and water heating solution.

NOTE: For additional information regarding this propylene glycol based, boiler type antifreeze that has been "Generally Recognized As Safe" by the FDA, please reference Appendix A, contact Aqua-Hot Heating Systems Technical Support Department at +1 (800) 685-4298, or visit our website at www.aquahot.com.

Winterizing the Domestic Water Heating System

The Aqua-Hot's domestic water heating system must be completely drained of domestic water at any time the heater is stored where freezing temperatures may be experienced.

NOTE: The Aqua-Hot can continue to be used for interior zone heat once the domestic water heating system has been drained and winterized.

Please follow these instructions when winterizing the Aqua-Hot domestic water heating system. Reference figure 4 for a system overview.

1. Completely drain the fresh water storage tank
2. Disconnect the domestic water demand pump suction line from the fresh water storage tank
3. Attach an adequate piece of hose onto the suction side of the domestic water demand pump
4. Place the opposite end of the hose into an adequate supply of FDA-approved "GRAS" RV antifreeze and allow the fluid to pump through
5. Open and close all interior and exterior water faucets one at a time, until ONLY pure RV antifreeze is present. Perform this procedure for both cold and hot water faucets
6. Remove the hose and reconnect the domestic water demand pump's suction line to the fresh water storage tank

Figure 4

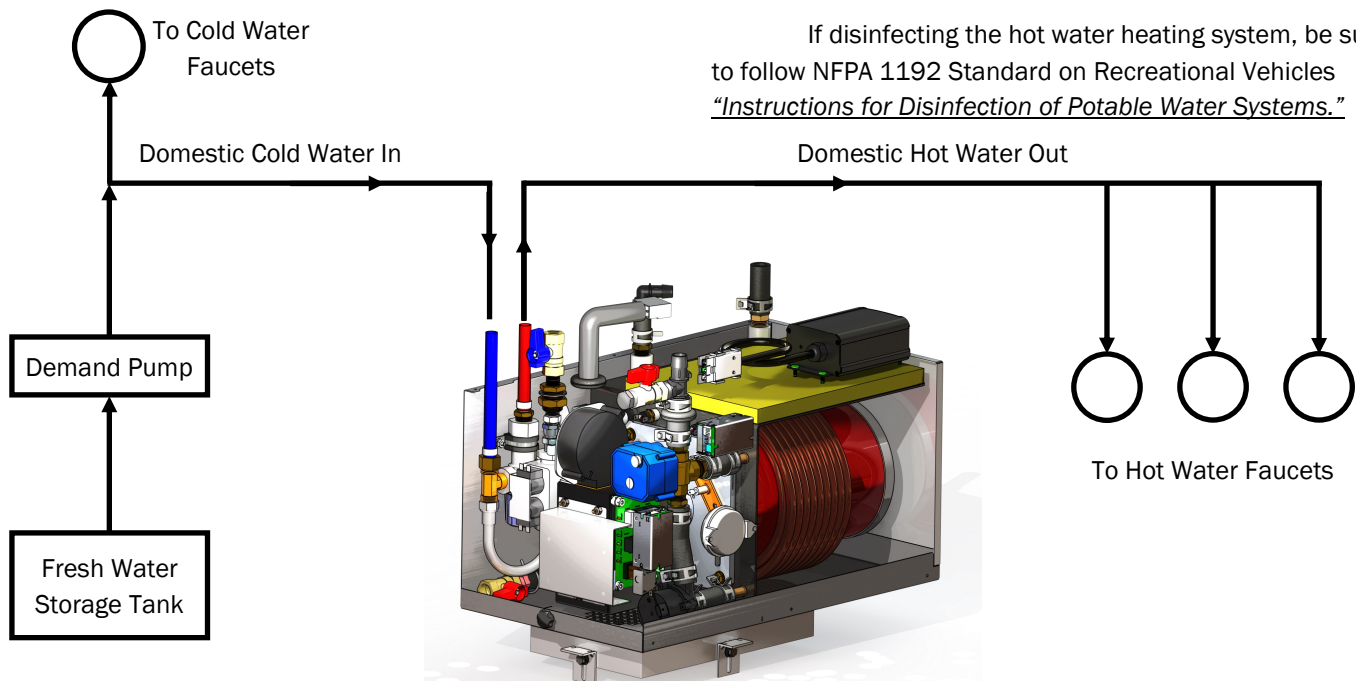

! WARNING

Not winterizing the Aqua-Hot when freezing temperatures are present will result in serious damage to the Aqua-Hot domestic water heating system. Ensure that FDA approved "GRAS" antifreeze rated for winterization is used when winterizing this unit.

De-Winterization

To de-winterize the Aqua-Hot system, completely fill the fresh water storage tank. Open and close the interior and exterior faucets, one at a time, until only clear water is present.

Disinfecting the Domestic Water System

NOTICE

Aqua-Hot systems contain copper tubing and are not compatible to prolonged exposure to sodium hypochlorite (bleach or liquid bleach.) Using products containing bleach, including water refreshers, may cause corrosion of the domestic water coil, resulting in a catastrophic failure of the Aqua-Hot system by creating leaks that cannot be repaired. This damage is not covered by the Aqua-Hot warranty.

If disinfecting the hot water heating system, be sure to follow NFPA 1192 Standard on Recreational Vehicles "Instructions for Disinfection of Potable Water Systems."

General Information

Should the Aqua-Hot Hydronic Heating System fail to operate, complete the following checks:

1. Verify that the Aqua-Hot's access cover is securely installed. The Aqua-Hot will not operate if the access cover is not fully installed.

NOTE: An interlock switch prevents the Aqua-Hot from operating when the cover is not installed and properly secured in place. Reference page 7 part #9 (250D) and page 8 part #14 (250P) for interlock switch locations.

2. Ensure that the vehicle's propane tank contains a sufficient level of fuel. The Aqua-Hot system will not operate if the fuel level is at or below 1/4 tank.
3. Ensure that the Aqua-Hot boiler tank has an adequate supply of antifreeze and water heating solution by checking the level at the expansion tank. If the level is low, reference the maintenance section of this guide for refilling instructions

NOTE: The fluid level sensor is located in the Aqua-Hot's expansion tank. If the antifreeze solution in the expansion tank drops below the level of the fluid sensor, the Aqua-Hot will not operate.

If the Aqua-Hot's failure to operate is not resolved with the aforementioned checks, please contact the Aqua-Hot Heating Systems Technical Support Department at **+1 (800) 685-4298** for additional assistance, or visit our website at **www.aquahot.com**.

Fluid will reach this line when Hot

Fluid Level Sensor

Figure 5

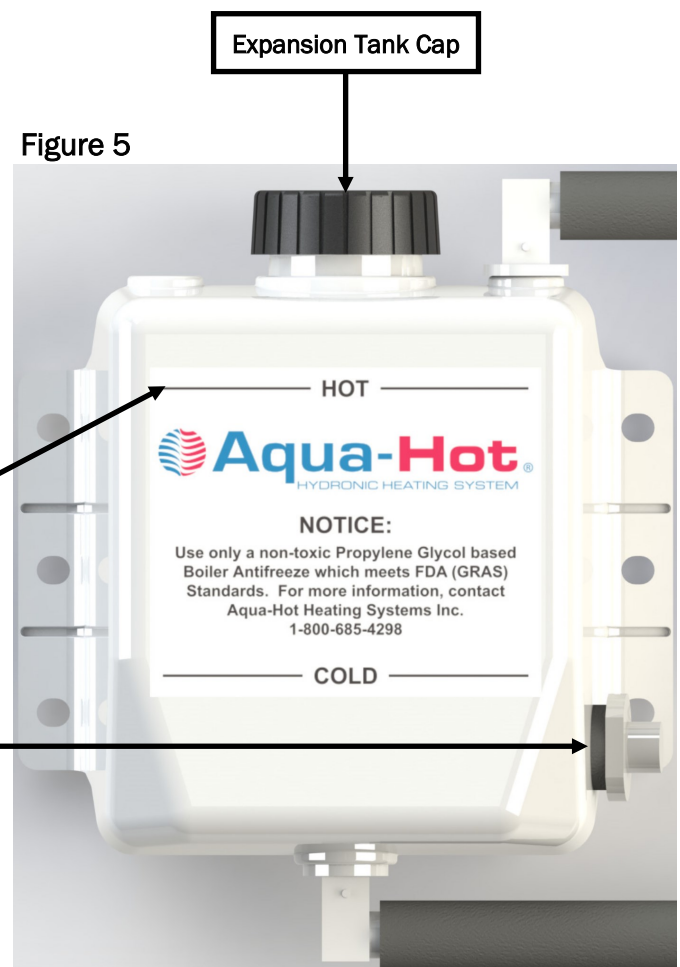

Appendix A: Antifreeze Types

The following information addresses the necessary usage of propylene glycol based “boiler” type antifreeze in the Aqua-Hot. Propylene glycol is a safer alternative to the more toxic ethylene glycol antifreeze; however, as mandated by the International Association Plumbing and Mechanical Officials (IAPMO,) only propylene glycol based “boiler” type antifreezes deemed “Generally Recognized As Safe” (GRAS) by the FDA should be utilized.

Due to the significant impact of various types of antifreeze on a hydronic heating system, including the level of safety provided, it has been recognized that there is a need to provide an explanation regarding two additional prominent types of antifreeze/coolant available. The following information should be utilized as an educational means of ensuring that the proper type of propylene glycol based antifreeze is selected.

RV & Marine Antifreeze

These types of propylene glycol based antifreeze products are formulated specifically for “winterizing” applications ONLY. Although RV and Marine antifreeze is often GRAS approved by the FDA, it should never be used in the Aqua-Hot’s Hydronic Heating System. This type of antifreeze is not formulated to transfer heat, which is essential to the heating system’s functionality and does not contain rust inhibitors. Please note that RV and Marine antifreeze can be utilized to winterize the Aqua-Hot’s domestic water coil for extended storage periods.

Automotive Antifreeze/Coolant

These types of propylene glycol based antifreeze products are formulated specifically to protect automotive engines against corrosion, freezing temperatures, and overheating. They also have excellent heat transfer and thermal conductivity characteristics. Although these types of antifreeze products are considered less toxic and safer than ethylene glycol for people, pets, and the environment, they are not GRAS rated by the FDA. Therefore, they must be marked with a “harmful if swallowed” warning. This additional warning is required because these types of antifreeze products contain high levels of chemical rust inhibitors. Due to their potentially hazardous properties, they should never be used in an Aqua-Hot heating system.

Appendix B: Antifreeze Mixture Water Quality Recommendations

In order to ensure maximum performance and longevity of an Aqua-Hot heating system’s boiler tank and associated components, it has been determined that there is a need to use distilled, de-ionized, or soft water in combination with concentrated propylene glycol for the Aqua-Hot’s antifreeze and water heating solution. Please note that this is only necessary when mixing concentrated propylene glycol antifreeze with water; suppliers of pre-mixed antifreeze are responsible for the use of high-quality (distilled, de-ionized, or soft) water when preparing their antifreeze for sale.

Hard water possesses a high-level of calcium and magnesium ions, which deplete the corrosion inhibitors in the propylene glycol. This causes the antifreeze and water heating solution to begin turning acidic, which can corrode the Aqua-Hot boiler tank and domestic water coil prematurely, thereby shortening the operational lifespan of the Aqua-Hot. Therefore, concentrated propylene glycol should be used with distilled, deionized, or soft water. The local water agency should have up-to-date water quality reports which will indicate if the local tap water is within our guideline of 80ppm of hardness or less.

Appendix C: Antifreeze Terms and Mixture Ratio

The following information addresses the process of selecting a propylene glycol based antifreeze solution that provides adequate freeze, boiling, rust, and corrosion protection. A 50/50 mixture ratio is recommended, which will result in a freeze point of approximately -28°F and a boiling point of approximately 222°F .

The following information should be utilized for the purpose of clarifying some terms commonly associated with antifreeze.

Freeze and Burst Point

Antifreeze solution lowers the freezing point of any liquid to which it has been added by preventing the formation of crystals. However, as the ambient temperature continues to decline, the water in the solution will attempt to attain a solid state. The point at which the water begins to solidify (or “gel”) is termed as the “freeze point.” Although the water in the solution has begun to freeze, producing a “slushy” consistency,

the antifreeze in the solution will continue to combat the normal expansion of the solution as it freezes. The point in which the solution can begin to expand due to colder temperatures is called the “burst point.” Once the solution reaches the burst point, the potential is present for ruptured pipes to exist. The burst point of the antifreeze and water solution is dependent upon the brand of propylene glycol antifreeze employed.

Boiling Point

The Aqua-Hot utilizes the propylene glycol based (PPG) antifreeze and water heating solution as a transportation means for the heat produced from the internal processes. The PPG antifreeze solution absorbs the heat created until its boiling point is reached. It is at this point when the liquid turns to a gas and is expelled to prevent the heating system from overheating. Each time the boiling point is reached, a loss of efficiency occurs because the heat produced is expelled rather than utilized for the function of the heating system. Therefore, a higher boiling point is desired in order to combat the loss of efficiency, which allows the antifreeze to transport the heat created from the internal process throughout the motorhome where it can be utilized productively rather than dissipating due to its change from a liquid to a gas.

Rust and Anti-Corrosive Inhibitors

Another major function of the antifreeze solution is to protect the internal metal components of the Aqua-Hot system from corrosion and rust. Antifreeze is able to perform this function by the addition of rust and corrosion inhibitors, which are designed specifically to activate in a water solution.

Summary

Antifreeze solution has three basic functions

1. Freeze Protection
2. Boil-over Protection
3. Anticorrosion and Rust Protection

PPG antifreeze solution is also primarily responsible for heat transfer; however, propylene glycol itself does not possess acceptable heat transfer characteristics. Therefore, water is added to the mixture due to its nature as an excellent heat conductor. PPG antifreeze solution, mixed with water that is 35% to 50% propylene glycol is recommended to provide the best performance combination of the aforementioned functions. If excess propylene glycol exists within the antifreeze and water heating solution, the water’s heat absorption properties will be compromised. This could ultimately inhibit the Aqua-Hot from providing adequate domestic hot water and interior heating.

Additionally if the antifreeze and water heating solution contains over 70% propylene glycol, the freezing point is raised, resulting in less freeze protection. Please reference the attached graphical representation regarding percentage of antifreeze to water and how it directly affects the solution’s freezing point.

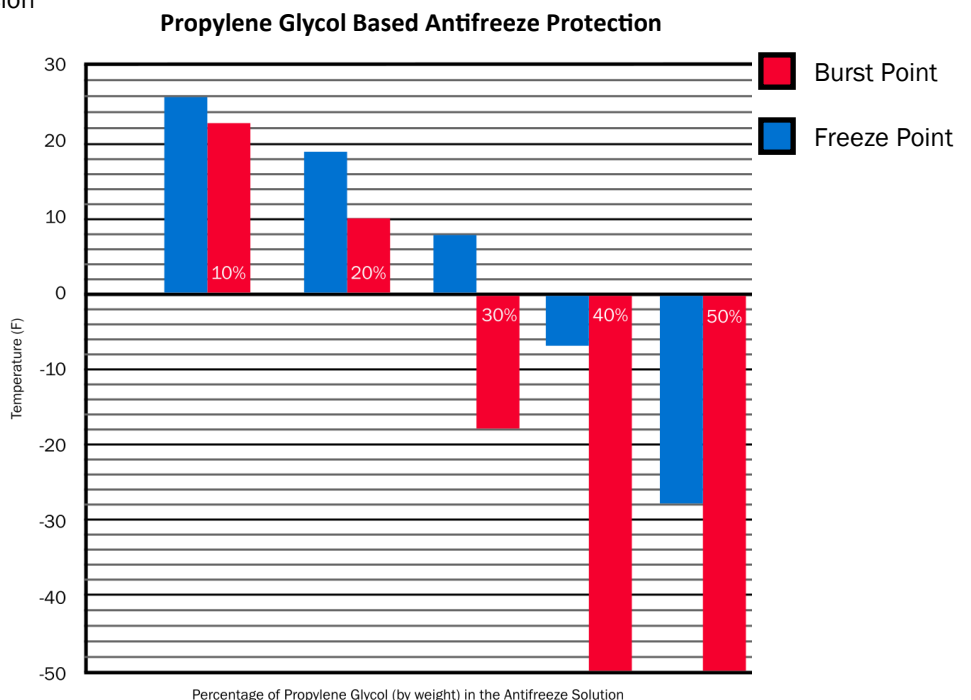

Appendix D: Measuring Propylene Glycol Using a Refractometer

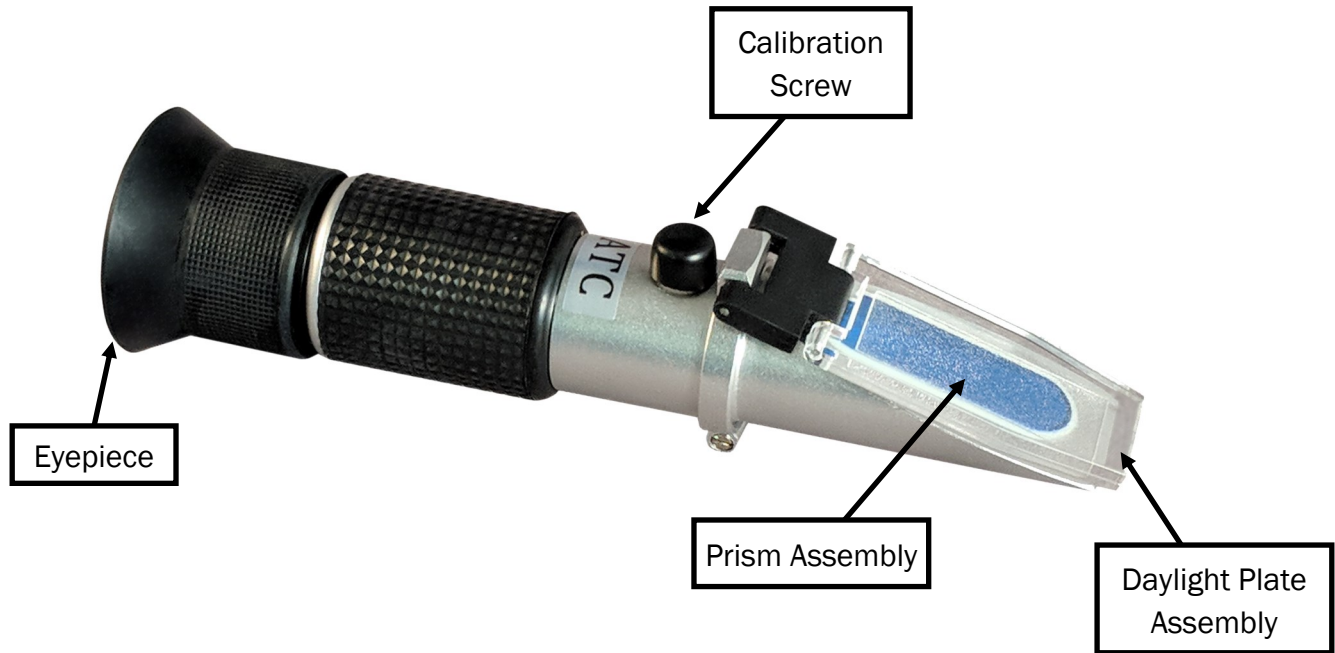

Properly Apply Antifreeze to the Prism Assembly

Use the guide below to properly apply the propylene glycol mixture to the prism assembly of the refractometer. Once that is complete, peer through the eyeglass of the refractometer to continue to the next step.

Adjust the Boundary Line

Once the glycol solution has been properly applied, adjust the calibration screw until the boundary line labelled "Propylene Glycol" is set to 32 °F. The graphic to the right has been designed as an aid, but note that it may differ from what is shown in the refractometer sight glass.

Refractometer Sight Glass

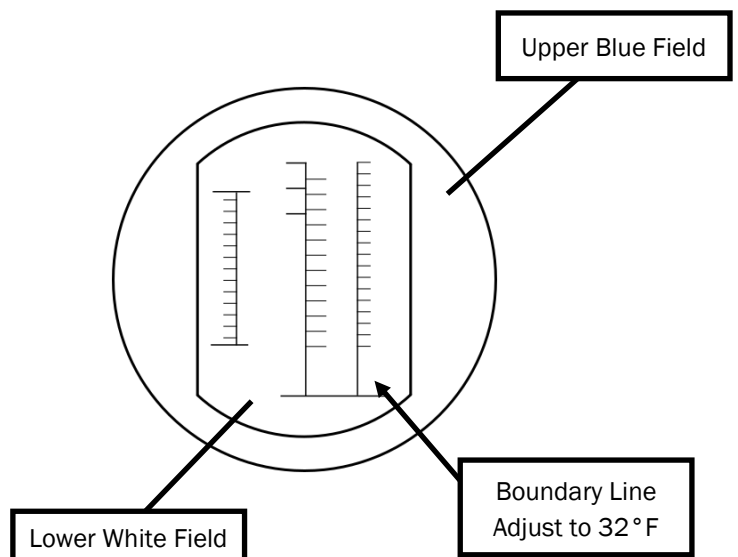

Application of Propylene Glycol

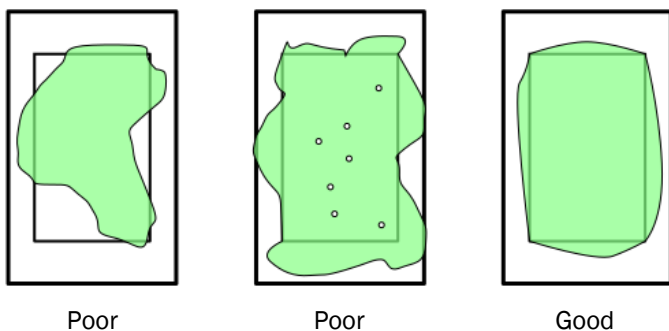

DATE	SERVICE PERFORMED	SERVICE CENTER

Service Log

DATE	SERVICE PERFORMED	SERVICE CENTER



2-YEAR LIMITED WARRANTY AQUA-HOT® HYDRONIC HEATING SYSTEM

Aqua-Hot Heating Systems Inc. warrants the Aqua-Hot Heater to be free from defects in material and workmanship under normal use and service for a period of two years on both parts and labor commencing upon the original date of registration of the vehicle. Replacement parts are warranted for the remainder of the Heater's standard warranty coverage or for six months, whichever is greater. The intent of this warranty is to protect the heater's end-user from such defects, which would occur in the manufacturing of the product. Thus, problems due to improper specifications, improper installations, improper use, the use of accessory parts or parts not authorized by Aqua-Hot Heating Systems Inc., repair by unauthorized persons, and damage or abuse of the heater are specially excluded from warranty coverage.

For additional information, or to obtain a warranty repair authorization, please contact the *Aqua-Hot Heating Systems Warranty Administrator* at 1-800-685-4298 (7:00 AM to 4:00 PM Mountain Standard Time) or visit www.aqua-hot.com.

My Comfort Zones are On-Board

Vehicle:

Purchased From:

Dealer Information:

Name:

Location:

Phone Number:

Heating System:

Serial Number:

LTE-300-000 Rev C

200 SERIES

 Aqua-Hot®

250P and 250D



Aqua-Hot Heating Systems, Inc.
7501 Miller Drive, Frederick, CO 80504

Visit us on line at www.aquahot.com
Call us at (800) 685-4298 or (303) 651-5500

©2018 Aqua-Hot Heating Systems Inc. Printed In U.S.A.